

# LENS CATALOG



# Content

## Lenses for mirrorless system cameras

### ■ Di III full-frame and APS-C

Highlight: 35-150mm F/2-2.8 .....	10
Fast E-mount Trinity .....	13
Fixed focal lengths .....	16
Fast all-in-one zoom .....	18
Compact telephoto zooms .....	20

### ■ Di III-A APS-C

Practical travel zoom .....	24
Compact zoom duo .....	26

## Lenses for digital SLR cameras

### ■ Di full-frame and APS-C

Fast SP zoom duo .....	30
Top fixed focal length .....	32
Powerful telephoto zooms .....	33

### ■ Di II full-frame and APS-C

Compact travel zooms .....	34
----------------------------	----

About TAMRON .....	36
Warranty and Service .....	37
Technology .....	38
TAMRON Lens Utility .....	41
Lens Table .....	42

**Because every moment counts**



For over 70 years, photographers around the world have chosen TAMRON every day. Our lenses preserve unique moments in the most beautiful memory.



# The advantages of TAMRON lenses

TAMRON's range of lenses covers the entire spectrum of photography. Whether it's a family vacation, a photo tour or a professional fashion shoot - with our zoom lenses and fixed focal lengths you will succeed in taking impressive pictures.



## Maximize the potential of your camera with TAMRON lenses.

High imaging performance, intuitive operation and compact design are the key features of TAMRON's modern photographic lenses. Our products offer you many advantages:

### 1 Light and compact

TAMRON lenses are lightweight and compact. You can shoot with them carefree and will always want to take them with you. The Di-III and Di-III-A models are specially designed for mirrorless system cameras.

### 2 Short close-up distance

With TAMRON lenses, you can photograph subjects very close up. The short focus distance enables close-up shots with a fascinating sharpness-blur gradient. Zoom lenses have never been more versatile!

### 3 Practical design

TAMRON lenses have a rugged, weatherproof body. Advanced coating makes cleaning the front lens easy. And the predominantly uniform filter size (ø 67 mm) has the advantage that filters and caps can be used on several lenses.



## Expand your creativity! Recommended combinations (examples)

### World's lightest Trinity series



The three fast zoom lenses for mirrorless full-frame cameras together weigh just 1,770 g.

### Versatile zoom combo



The two compact zoom lenses for mirrorless APS-C cameras are together 860 g light.

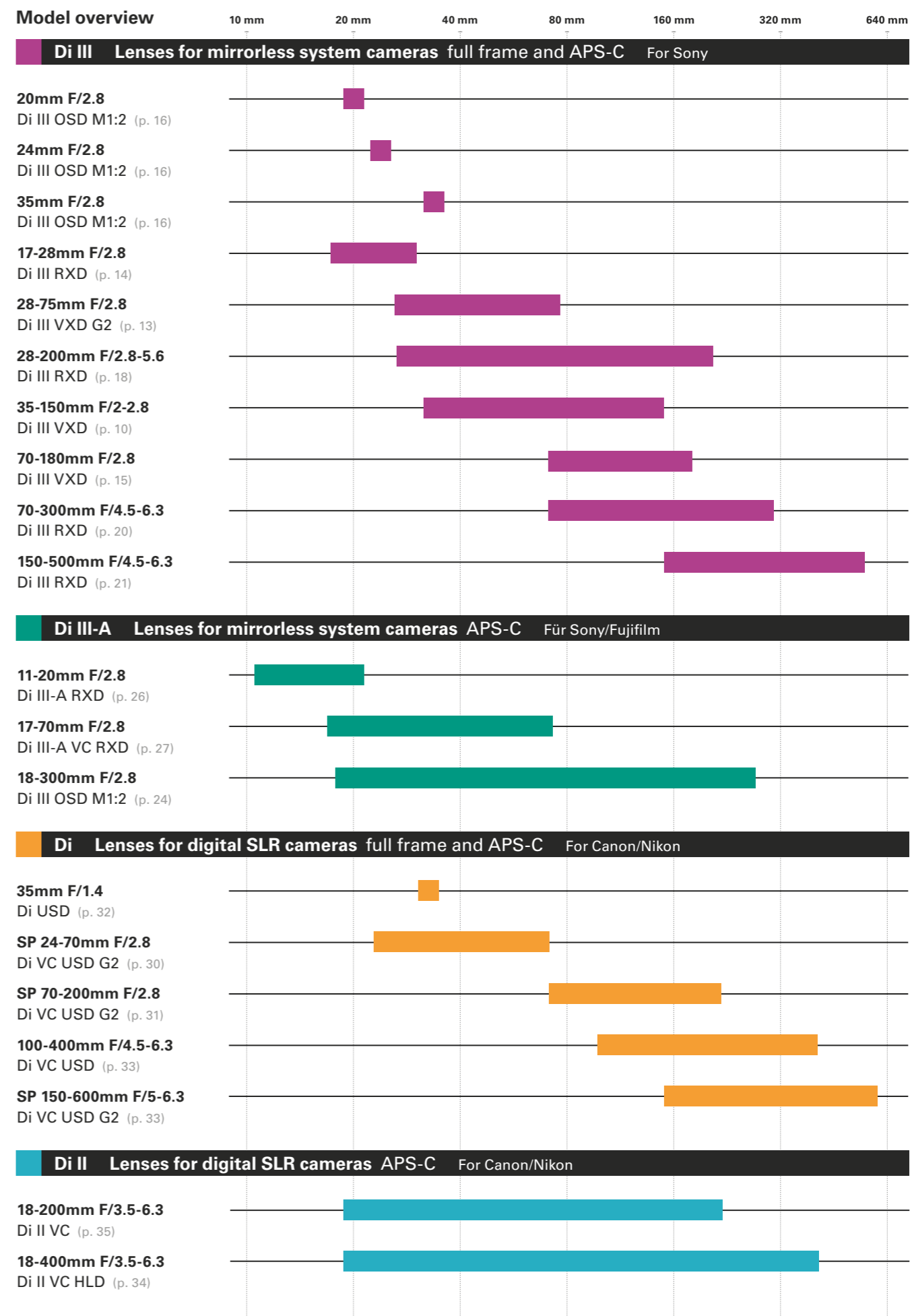

The Di-III and Di series lenses can be used on both full-frame and APS-C cameras. In the Di-III-A series, the 18-300mm F/2.8 is also available with mount for Fujifilm X-Mount. TAMRON lenses for digital SLR cameras (Di and Di II) can also be used on the adapters, TAMRON lenses for digital SLR cameras (Di and Di II) can also be used on Canon and Nikon mirrorless system cameras.









17-28mm at 17 mm · F/2.8 · 1/3200 s · ISO 100 | Photo: Long-Nong Huang

Di III

# Lenses for mirrorless System cameras

For Sony\*

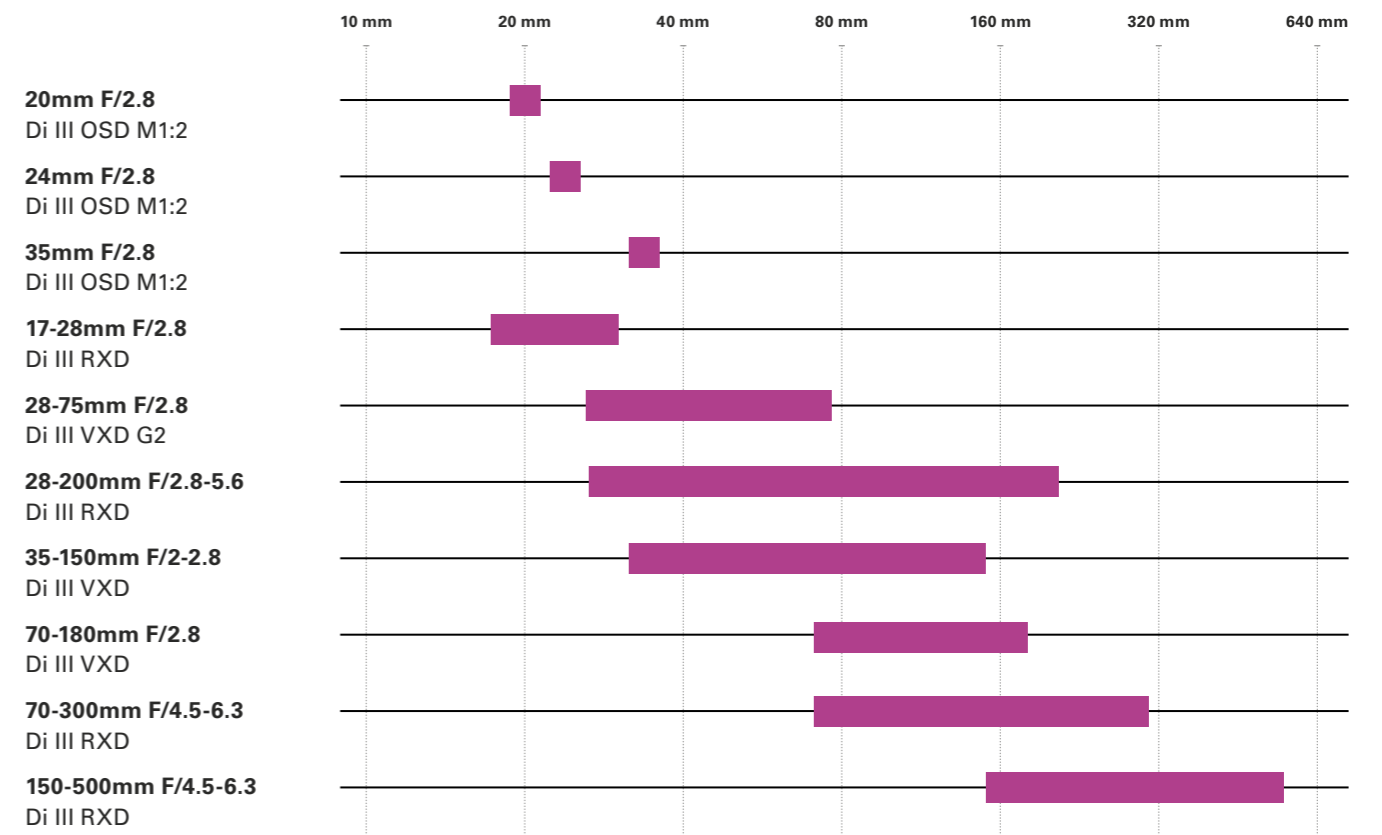

\* All lenses of TAMRON's Di-III series can be used on both full-frame and APS-C as well as on APS-C cameras with Sony E-mount.



# 35-150mm F/2-2.8

## The top lens for all situations

The world's first all-in-one zoom with F/2 aperture for mirrorless full-frame system cameras with a design that is as elegant as it is robust. An outstanding lens in every respect.



The 35-150mm F/2-2.8 Di III VXD is an exceptional all-in-one zoom lens in every respect. It is suitable for all typical shooting situations in travel photography - from landscapes and architecture to portraits, group shots and everyday snapshots, even in low-light scenes. The design of the 35-150mm F/2-2.8 is trend-setting. The focus and zoom rings have a better grip thanks to a new ribbing. The glossy surface is particularly resistant to scratches and dirt



### 35-150mm F/2-2.8 Di III VXD

With the fast VXD autofocus, every moment can be captured sharply in the picture. The wide focal length range from 35 mm wide-angle to 150 mm telephoto, the very high speed and the advanced technology make this lens something special. Despite its performance, the lens weighs only 1,165 g and measures just 158 mm in length.

Di III VXD MR ASL LD IF ZL FLR

FOR FULL FRAME & APS-C SONY DSLM

Model A058 TAMRON LENS UTILITY



Photos: Thomas Adorff







# E-Mount Trinity

## For moments when absolute top performance is required

17-28mm, 28-75mm and 70-180mm - this trio sets new standards. With F/2.8 aperture and compact dimensions, these zoom lenses are ideal for a variety of different uses.

The E-mount Trinity represents the most advanced lens technology. The three fast zoom lenses - the 17-28mm F/2.8 Di III RXD, the 28-75mm F/2.8 Di III VXD G2 and the 70-180mm F/2.8 Di III VXD - represent optical excellence and innovation. The core characteristics of the Trinity lenses include exceptionally high resolving power and natural color and contrast reproduction. With a continuous open aperture of F/2.8 across the entire focal length range of 17mm to 180mm, they are the first choice for those who strive for uncompromising image quality.

"The E-mount Trinity is the ideal combination for demanding photo and video shoots," confirms Cologne-based photographer duo Sallyhateswing. Sarah and Phil regularly shoot for lifestyle magazines that place great emphasis on sharpness and detail. Their conclusion: "With the Trinity, we have exactly the lenses we need for high-end image series."

### ADVANTAGES AT A GLANCE E-MOUNT TRINITY

#### 1. high speed

The continuous aperture of F/2.8 offers maximum creative freedom and ensures beautiful bokeh. The main subject can be brought into sharp focus against a soft background.

#### 2. light and compact

TAMRON's E-mount zoom lenses are very compact and lightweight. Combined with a mirrorless system camera, they are perfectly balanced and weigh only 1,770 g.

#### 3. fast and quiet autofocus

RXD and VXD autofocus are designed specifically for compact system cameras. They focus on the subject quickly, precisely and silently - ideal not only for photos, but also for first-class video recording.

### 28-75mm F/2.8 Di III VXD G2

Fast and robust top-class zoom lens with LD and GM lens elements for maximum image quality. Suitable for a wide variety of subjects, from portraits to landscapes and architecture to close-ups at a magnification of 1:2.7. At 117.6 mm in length and 540 g in weight, it is particularly lightweight and compact.

Di III VXD MR XLD LD IF FLR  
FOR FULL FRAME & APS-C SONY DSLM  
Model A063 TAMRON LENS UTILITY



"The 28-75mm G2 is phenomenal. Even the finest details are rendered razor sharp."

Sallyhateswing,  
Lifestyle and fashion photographers,  
Cologne





17-28mm at 28 mm · F/6.3 · 1/400 s · ISO 160

Photo: Philip Ruopp

"The first thing that impressed me about the 17-28mm is its compact size," says Philip Ruopp. "It's small and extremely lightweight at 420 grams. And then the high quality of the photos is all the more amazing. But for me, the auto-focus in particular has to be really on its toes. And there I was not disappointed. The high hit rate with continuous autofocus was really impressive."



### 17-28mm F/2.8 Di III RXD

Fast wide-angle zoom lens for particularly dynamic perspectives. With a length of 99 mm and a weight of just 420 g, it is exceptionally compact and lightweight for its class. LD and XLD lenses guarantee brilliant imaging performance.

Di III RXD MR XLD LD IF FLR  
FOR FULL FRAME & APS-C SONY DSLM Model A046



70-180mm at 180 mm · F/2.8 · 1/160 s · ISO 100 | Photo: Long-Nong Huang

"The 70-180mm is my favorite lens. It allows you to bring the subject into the picture in a big way, and effectively condense the frame."

Long-Nong Huang,  
Outdoor and nature photographer,  
Freiburg



### 70-180mm F/2.8 Di III VXD

The pleasantly compact and lightweight high-speed telephoto zoom is equipped with the innovative VXD autofocus and is fully compatible with the camera's fast Hybrid AF and Eye AF. As with most lenses in the E-mount series, filters with a diameter of 67 mm can be screwed on.

Di III VXD MR XLD LD IF FLR ZL  
BBAR G2 FOR FULL FRAME & APS-C SONY DSLM

Model A056



70-180mm at 70 mm · F/2.8 · 1/500 s · ISO 320

Photo: Long-Nong Huang



17-28mm at 17 mm · F/4 · 1/2500 s · ISO 200 | Photo: Philip Ruopp



# 20mm, 24mm und 35mm Minimalism and perfection - the soul of photography

Three fast wide-angle lenses with open aperture F/2.8, uniform dimensions and large magnification. These fixed focal lengths give new expression to your creativity.



## 20mm F/2.8 Di III OSD M1:2

The wide angle of view of this ultra-wide-angle lens is optimal for fascinating image compositions and sweeping panoramas. With the short closest focusing distance of only 0.11 m, images with strong perspective and dramatic depth are achieved.

Di III OSD MR FLR LD  
FOR FULL FRAME & APS-C SONY DSLM

Model F050

## 24mm F/2.8 Di III OSD M1:2

Handy super wide-angle lens for captivating reportage and landscape shots. The low closest focusing distance (0.12 m) allows exciting close-up shots with a magnification of 1:2. As with most E-mount lenses from TAMRON, the filter diameter is 67 mm.

Di III OSD MR FLR LD  
FOR FULL FRAME & APS-C SONY DSLM

Model F051

## 35mm F/2.8 Di III OSD M1:2

With a length of 64 mm and a diameter of 73 mm, this wide-angle lens has the same dimensions as the other fixed focal lengths in the E-mount series. The F/2.8 speed and the fast, quiet OSD autofocus are also among the common features of these lenses.

Di III OSD MR FLR LD  
FOR FULL FRAME & APS-C SONY DSLM

Model F053

"Compact fixed focal lengths represent a return to the core of photography."

Klaus Wohlmann,  
Travel and street photographer,  
Cologne



35mm · F/6.3 · 1/100 s · ISO 100 | Photo: Glynn Lavender





28-200mm at 28 mm · F/2.8 · 1/2500 s · ISO 100



28-200mm at 28 mm · F/2.8 · 1/200 s · ISO 200

## 28-200mm F/2.8-5.6 A fast all-in-one zoom, Thousands of unforgettable images

This all-purpose lens not only not only unique snapshots, but also great macro but also great macro shots.

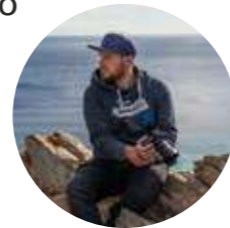

**"With aperture F/2.8 at focal length 28 mm the pictures a fascinating depth effect."**

Philip Ruopp,  
Outdoor and sports photographer,  
Laichingen



### 28-200mm F/2.8-5.6 Di III RXD

Several special lenses minimize chromatic aberrations and ensure uniformly high imaging performance in both the wide-angle and telephoto ranges. Despite the large zoom range and sophisticated optical design, the lens is only 117 mm long and weighs just 575 g.

Di III RXD MR XLD LD IF FLR ASL ZL  
FOR FULL FRAME & APS-C SONY DSLM Model A071

Whether landscape panoramas, portraits or telephoto shots full of details - with the wide zoom range of the 28-200mm F/2.8-5.6 Di III RXD, any subject can be captured in excellent image quality. Special lenses and the high speed of F/2.8-5.6 ensure sharp and brilliant photos even in low light.

Professional photographer Philip Ruopp is thrilled with the performance of the new all-in-one zoom. "At 28 mm, I can get as close as 0.19 m to the subject. Combined with the large open aperture F/2.8 and the seven rounded aperture blades, I get beautiful close-ups with a really charming background blur."



28-200mm at 200 mm · F/5.6 · 1/320 s · ISO 400



28-200mm at 200 mm · F/5.6 · 1/500 s · ISO 100

Fotos: Philip Ruopp



# Compact telezooms

## Faster, sharper, closer - more range for better pictures

Make distant subjects look big with these zoom lenses. Shooting with long telephoto focal lengths has never been easier or simpler.



### 70-300mm F/4.5-6.3 Di III RXD

The 70-300mm F/4.5-6.3 is TAMRON's first telephoto zoom with a 300mm focal length for mirrorless system cameras with full-frame sensors. The fast RXD autofocus ensures precise focus tracking even with dynamic subjects. Despite the long reach, it measures just 148mm and weighs only 545g - making it ideal for family and sports.

Di III RXD MR LD IF

FOR FULL FRAME & APS-C SONY DSLM Model A047



70-300mm at 231 mm · F/5.6 · 1/320 s · ISO 100

Photo: Marcie Reif



150-500mm at 150 mm · F/5.6 · 1/3200 s · ISO 800 | Photo: Oliver Güth



70-300mm at 300 mm · F/6.3 · 1/320 s · ISO 1000 | Photo: Marcie Reif

Milliseconds count in sports. Freezing a movement at exactly the most expressive moment - the 150-500mm F/5-6.7 was developed for this purpose. For an ultra-telephoto zoom lens, it is surprisingly handy and yet offers exceptional image quality. Individual hairs, fine pores or beads of sweat are reproduced razor-sharp. The VXD autofocus literally sticks to the subject in dynamic scenes, while the VC image stabilizer ensures sharp images in any situation.

**"This zoom lens is a gamechanger. Never before has with ultra-telephoto focal lengths has never been so comfortable and intuitive."**

Oliver Güth,  
Lifestyle and sports photographer,  
Cologne



### 150-500mm F/5-6.7 Di III VC VXD

The optical system of this ultra-telephoto zoom lens consists of 25 lens elements, including several special glasses and hybrid aspheres to correct aberrations. Despite the high imaging performance, the lens weighs only 1.725 kg and is wonderfully compact at just 20.96 cm in length.

Di III VXD VC XLD LD MR IF ASL

BBAR G2 FLR ZL FOR FULL FRAME & APS-C

SONY DSLM Model A057





DI III-A

# Lenses for mirrorless System Cameras with APS-C sensor

For Sony and Fujifilm\*

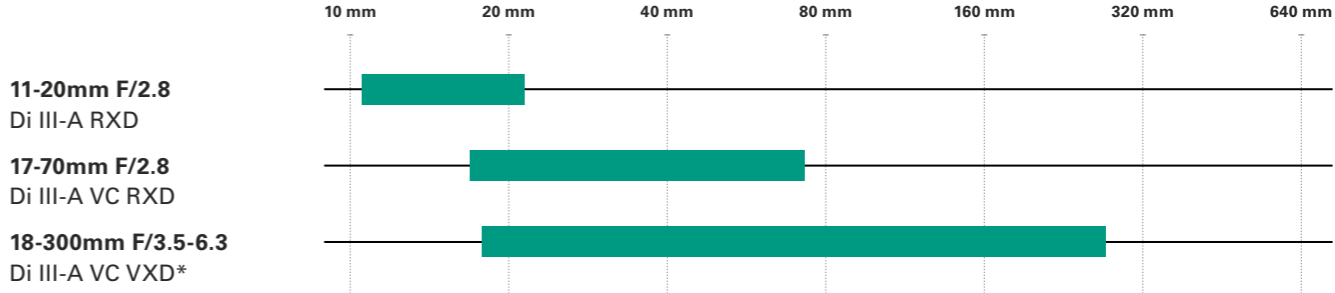

\* All lenses of the Di-III-A series from TAMRON are available with mount for Sony E-Mount available. The 18-300mm F/3.5-6.3 Di III-A VC VXD is also available with mount for Fujifilm X-Mount.



# 18-300mm F/3.5-6.3

## Whether near or far - no subject is too far no subject is too far for this travel zoom

With this universal zoom, your next photo tour will be an unforgettable experience. The long reach and short close-up distance enable impressive images in any situation.

A lens with all focal lengths from wide-angle to ultra-telephoto! The 18-300mm F/3.5-6.3 Di III-A VC VXD is the world's first zoom lens with 16.6x magnification for mirrorless APS-C cameras. With a wide focal length range of 27mm to 450mm (KB equivalent), it offers all the benefits of all-in-one zoom lenses suitable for a wide range of photographic applications.



### 18-300mm F/3.5-6.3 Di III-A VC RXD

Several special glasses ensure excellent image quality with high resolving power right to the edge of the image. The short close-up distance of only 0.15 m at 18 mm focal length enables close-up shots with an image scale of 1:2. At 620 g and 125.6 mm, the 18-300mm F/3.5-6.3 is pleasingly lightweight and compact. The filter diameter is 67 mm, as with most E-mount lenses.

Di III-A VXD VC FLR MR LD ASL IF ZL  
FOR APS-C FUJIFILM DSLM SONY DSLM Model B061



18-300mm at 95 mm · F/5.6 · 1/2000 s · ISO 200

Photo: Philip Ruopp

#### ADVANTAGES AT A GLANCE 18-300mm F/3.5-6.3

##### 1. long range

With its wide focal length range, this travel zoom lens is suitable for panoramic images as well as natural portraits and detailed close-ups.

##### 2. light and compact

Advanced technologies and materials ensure compact dimensions and light weight, so you'll always want to take your travel zoom lens with you.



18-300mm at 34 mm · F/8 · 1/130 s · ISO 200 | Photo: Philip Ruopp



18-300mm at 300 mm · F/6.3 · 1/250 s · ISO 320 | Photo: Philip Ruopp



# Compact zoom duo

## Ultra-telephoto zoom with intuitive, comfortable operation

The two zoom lenses for mirrorless APS-C cameras together weigh only 860 g on the scales. The ideal pair of lenses for anyone who likes to spend a lot of time outdoors.

"With this ultra-wide-angle zoom photos and videos and videos with wow effect."

Shawn Ogulu,  
Freelance Content Creator,  
Durban, South Africa



### 11-20mm F/2.8 Di III-A RXD

The 105-degree angle of view is not only suitable for spectacular panoramas, but in combination with the shortest setting distance of only 15 cm also for close-up shots with dramatic depth effect. Special XLD and LD lens elements ensure brilliant shots with attractive contrasts and natural colors.

Di III-A RXD XLD LD FLR BBAR G2 MR IF  
FOR APS-C SONY DSLM Model B060



17-70mm at 17 mm · F/3.2 · 1/1000 s · ISO 100 | Photo: Luke Stackpoole



11-20mm at 11 mm · F/5 · 1/400 s · ISO 80 | Photo: Shawn Ogulu

This zoom duo is unique in terms of compactness, speed and image quality: the 11-20mm and the 17-70mm together cover the entire focal length range from 11 mm to 70 mm (KB equivalent 16.5 mm to 105 mm) with a constant speed of F/2.8. Nevertheless, the fast combination weighs only 860 g. Both are therefore the ideal choice for those who like to travel light and want to capture their experiences in outstanding images.



### 17-70mm F/2.8 Di III-A VC RXD

The innovative zoom lens has a universal focal length range and high speed. The fast autofocus with RXD technology and the integrated VC image stabilization guarantee high image sharpness. Only 119.3 mm long and 525 g light, it is an ideal all-round lens.

Di III-A RXD MR XLD LD IF FLR VC ASL  
FOR APS-C SONY DSLM Model B070



17-70mm at 17 mm · F/2.8 · 1/200 s · ISO 200

Photo: Luke Stackpoole





Di Di II

# Lenses for digital SLR cameras

For Canon and Nikon

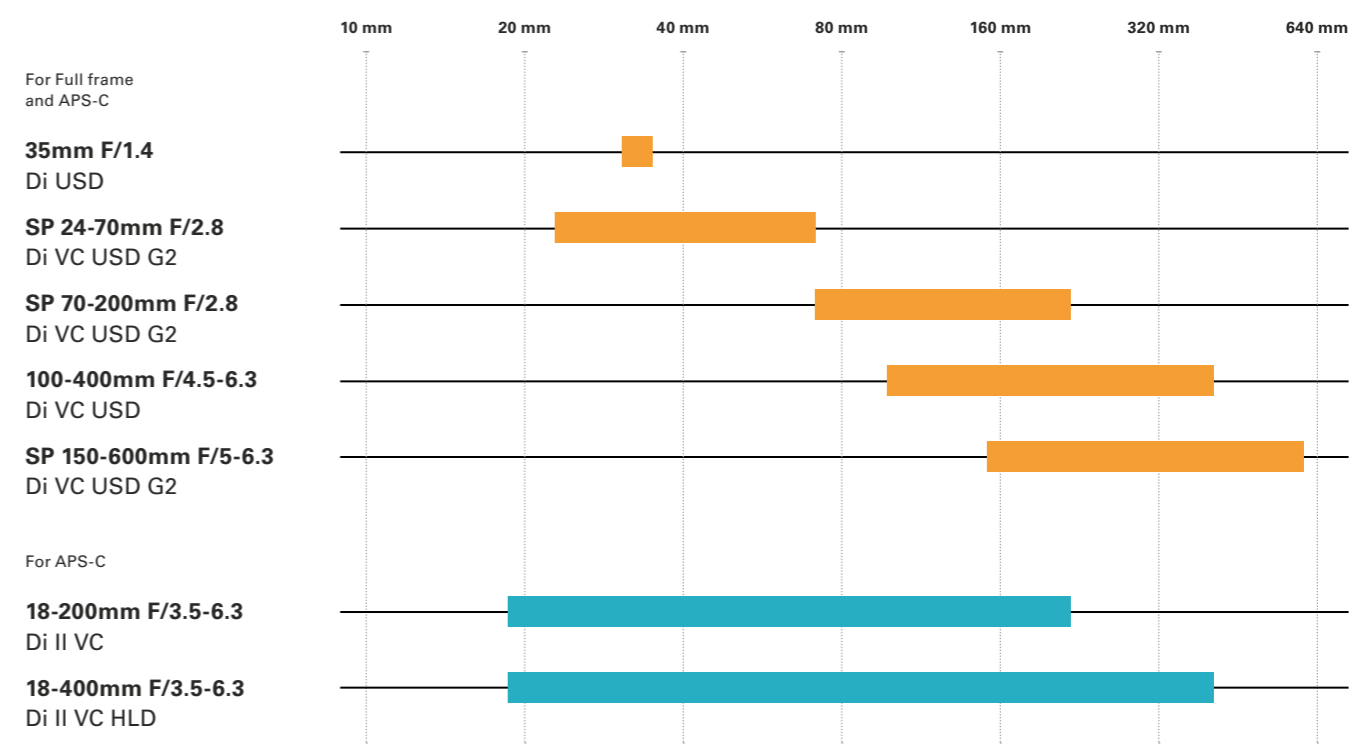

Mirrorless with adapter

All TAMRON lenses for digital single-lens reflex cameras can also be used on mirrorless system cameras from Canon and Nikon. Corresponding adapters are available in stores. Further information: [www.tamron.eu/de/service/kompatibilitaet-nikon-z-und-canon-eos-r/](http://www.tamron.eu/de/service/kompatibilitaet-nikon-z-und-canon-eos-r/)



# Superior Performance

## Top lenses for the highest demands

The SP zoom duo SP 24-70mm F/2.8 and SP 70-200mm F/2.8 leaves nothing to be desired. and is part of the standard equipment of demanding photographers.



### SP 24-70mm F/2.8 Di VC USD G2

High-speed standard zoom lens of the latest generation, specially designed to meet the high demands of photo professionals. The advanced optical design with 2 XR, 3 LD and 3 GM elements guarantees exceptionally high imaging performance.

Di SP VC USD MR FLR eBAND LD ZL  
IF DMPU FOR FULL FRAME & APS-C  
CANON DSLR NIKON DSLR Model A032

"With the fast SP Zooms, I capture weather phenomena exactly as I have seen and experienced them myself."

Bastian Werner,  
Weather and landscape photographer,  
Mühltal



SP 24-70mm at 50 mm · F/9 · 1/800 s · ISO 125 | Photo: Bastian Werner



SP 70-200mm at 200 mm · F/2.8 · 1/200 s · ISO 100 | Photo: Thomas Kettner

### ADVANTAGES AT A GLANCE SUPERIOR PERFORMANCE

#### 1. high luminous intensity and image quality

High-quality special optical glass guarantees excellent imaging performance. The constant aperture of F/2.8 offers maximum creative freedom.

#### 2. robust and weatherproof construction

SP lenses are designed for extreme daily use. The metal housing is sealed and the front lens is protected from dirt with a fluorine coating.



### SP 70-200mm F/2.8 Di VC USD G2

Compact, fast telephoto zoom for professional use with excellent optical performance, powerful VC image stabilizer (5 EV stops\*) and ultra-fast, precise USD autofocus. The short focusing distance of 0.95 m allows detailed close-ups.

Di SP VC USD MR FLR eBAND LD ZL  
IF DMPU FOR FULL FRAME & APS-C  
CANON DSLR NIKON DSLR Model A025

"High image quality and impressive features - the price-performance ratio of the SP series is simply unbeatable."

Thomas Kettner,  
Advertising and fashion photographer,  
Hamburg

\* Compensation over 5 EV steps according to CIPA standard in VC mode 3 (maximum stabilization).





SP 35mm · F/1.4 · 1/800 s · ISO 100 | Photo: Sallyhateswing

# Telezooms for DSLR cameras

## Close to the action

With these telephoto lenses, even distant subjects can be captured full-frame in the blink of an eye. They're the ideal choice for anyone who wants to capture great sports and wildlife photos with their DSLR.



### 100-400mm F/4-6.3 Di VC USD

Handy super telephoto zoom lens with a long range that can be additionally extended with a TAMRON teleconverter. The dual MPU ensures very precise focusing even with continuous autofocus (AF-C), with simultaneous image stabilization. The tripod clamp is available as an optional accessory.

Di VC USD LD MR FLR eBAND  
ZL IF DMPU FOR FULL FRAME & APS-C  
CANON DSLR NIKON DSLR Model A035



100-400mm at 400 mm · F/6.3 · 1/5000 s · ISO 640

Photo: Oliver Güth



### SP35mm F/1.4 Di USD

Developed to celebrate the 40th anniversary of the SP series, this very fast wide-angle lens offers the ultimate in optical performance. The 14 optical elements, including 4 LD and 3 GM lenses, are coated with the new BBAR-G2 coating, which ensures high brilliance even when shooting against the light.

Di SP USD LD FLR  
FOR FULL FRAME & APS-C CANON DSLR NIKON DSLR

Model F045



SP 35mm · F/1.4 · 1/800 s · ISO 100

Photo: Sallyhateswing

**"The fabulous sharpness right to the edges of the image excited us from the start. And you can see that in the photos."**

Sallyhateswing,  
Lifestyle and fashion photographers,  
Cologne



### SP 150-600mm F/5-6.3 Di VC USD G2

Powerful ultra-telephoto zoom lens, especially for ambitious wildlife and sports photography. Three VC image stabilization modes, three LD elements, and eBAND and BBAR coatings ensure very high image quality. With Flex Zoom Lock for fast determination of the focal length.

Di SP VC USD LD MR FLR eBAND  
ZL IF DMPU FOR FULL FRAME & APS-C  
CANON DSLR NIKON DSLR Model A022



150-600mm at 250 mm · F/8 · 1/3200 s · ISO 64

Photo: Bastian Werner





### 18-400mm F/3.5-6.3 Di II VC HLD

The 22.2x ultra-telephoto megazoom is a versatile travel companion. Despite its compact dimensions and low weight, it offers an enormous range of up to 600 mm (equivalent to 35 mm format). Even distant subjects can be brought into the picture in a big way. HLD autofocus and VC stabilization ensure successful, sharp shots even in low light.

Di II VC HLD MR IF ZL LD  
FOR APS-C CANON DSLR NIKON DSLR Model B028



18-400mm at 18 mm · F/5.6 · 1/13 s · ISO 500

Photo: Philip Ruopp

"This compact and lightweight all-in-one lens combines the art of photography with the joy of travel."

Philip Ruopp,  
Outdoor and sports photographer,  
Laichingen



18-200mm at 18 mm · F/5.6 · 1/200 s · ISO 400 | Photo: Thomas Kettner



18-400mm at 75 mm · F/5 · 1/20 s · ISO 500 | Photo: Philip Ruopp



18-200mm at 18 mm · F/5.6 · 1/125 s · ISO 400

"The image quality of this 400 g lightweight lens is simply impressive - and across the entire zoom range from 18 mm to 200 mm."

Thomas Kettner,  
Advertising and fashion photographer,  
Hamburg



### 18-200mm F/3.5-6.3 Di II VC

Classic high-power zoom lens for APS-C cameras that brings all the advantages of a perfect travel lens for beginners: it is not only compact, lightweight and robust, but also has a long telephoto range that allows you to zoom in on distant subjects or fascinating details.

Di II VC ASL LD IF ZL  
FOR APS-C CANON DSLR NIKON DSLR Model B018



# About TAMRON

Since its founding in 1950, TAMRON Co, Ltd. has been developing high-precision optical products for a wide range of applications.

In addition to photographic lenses, TAMRON manufactures optical systems for use in industrial, transportation, and security applications, among others. We employ approximately 5,000 people worldwide. The company headquarters are located in Saitama, north of Tokyo. There are subsidiaries in the USA, Germany, France, Russia, China and India. The branch office of TAMRON Europe GmbH in Cologne was founded in 1982. Today, about 70

people work here. Lenses and components are produced in two plants in northern Japan and in two modern manufacturing facilities in China and Vietnam.

The company name TAMRON goes back to the optical engineer Uhyou Tamura, who laid the foundation for TAMRON's success with his technological developments



The 135 mm F/4.5 (model 280) is the first interchangeable lens from TAMRON



TAMRON Europe Headquarters in Cologne

## HISTORICAL MILESTONES

**1957**

The 135mm F/4.5 is TAMRON's first interchangeable lens for SLR cameras

**1961**

The industrially produced 95-205mm F/6.3 is the first affordable SLR telephoto lens

**1966**

TAMRON Adapt-A-Matic interchangeable lenses with autofocus function

**1979**

The SP (Superior Performance) series makes its debut

**2015**

"Human Touch" redesign of the SP series and all new lenses

**2017**

The 18-400mm F/3.5-6.3 is the world's first 22.2x ultra-telephoto megazoom SLR lens

**2018**

Launch of new generation of lenses for Sony E-mount

**2020**

World's first 17-70mm F/2.8 zoom for mirrorless APS-C cameras with E-mount

**2021**

The 35-150mm F/2-2.8 is the first 4x zoom with F/2 aperture for mirrorless cameras with E-mount

# Warranty and service

Our customer service will help you with questions about your lens and technical problems.

## 5 years warranty

The quality of TAMRON lenses is guaranteed. In addition, we offer you a free warranty extension to five years. To claim this in the event of a material defect, register your lens online within two months of purchase. Learn more at: [www.tamron.eu/service/5-year-warranty](http://www.tamron.eu/service/5-year-warranty)



## Repairs

The quality of TAMRON products is carefully checked. However, should any fault occur, please contact our customer service team. If the fault is within the terms of our warranty, we will repair the lens free of charge, or in some circumstances may offer a suitable replacement should repair not be possible. If the repair is not covered by our manufacturers warranty, then we will provide a quotation for the repair for your consideration.

## Customer service

TAMRON Europe GmbH  
Customer service  
Robert-Bosch-Straße 9  
50769 Cologne  
Tel. +49 (0) 221 669 544-135  
[service@tamron.de](mailto:service@tamron.de)  
Mo to Th 8.30 am till 16.30 pm  
Fr 8.30 am till 15.00 pm

More information:  
[www.tamron.eu/de/service](http://www.tamron.eu/de/service)





# Technology

TAMRON is one of the world's leading companies in the optical industry. Our success is based on the relentless pursuit of perfection and innovation. All lenses feature the most advanced technologies.

## Special optical glasses

### LD and XLD lens elements

**LD** **XLD** LD (Low Dispersion) and XLD (eXtra Low Dispersion) elements are made of glass materials with low color dispersion indices. They reduce chromatic aberrations (color fringes). XLD elements have an extremely low color dispersion index and, like fluorite elements, are suitable for correcting aberrations even in critical peripheral areas.

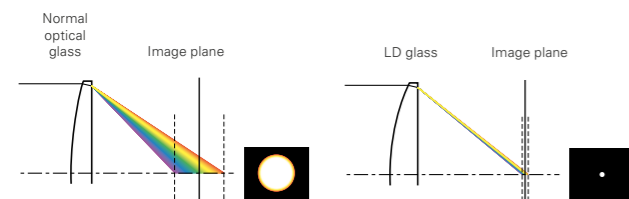

Schematic diagram of the chromatic aberration with a normal optical glass (left) and an LD glass (right)

### Hybrid aspherical elements

**ASL** The abbreviation ASL (ASpherical Lens) refers to hybrid aspherical lens elements. These correct typical imaging errors of zoom lenses, for example spherical aberrations (focus errors). They are suitable for particularly compact lenses, since they promote a more compact design while maintaining the same high imaging quality.

### AD elements

**AD** Optical lenses with abnormal dispersion (AD) help to reduce chromatic aberrations at high light frequencies. By combining AD elements with different lenses made of normal optical glass, it is possible to control the light dispersion of specific wavelengths.

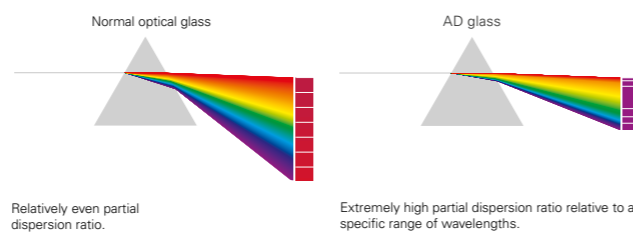

### Focal length comparison

Top row: Small format - large format  
Bottom row: APS-C sensor (crop factor 1.55)

\*equivalent to small format - large format

### FOCAL LENGTH COMPARISON

On 35 mm / full-frame sensor (top row) and APS-C sensor (bottom row).

\* Equivalent to 35 mm / full frame

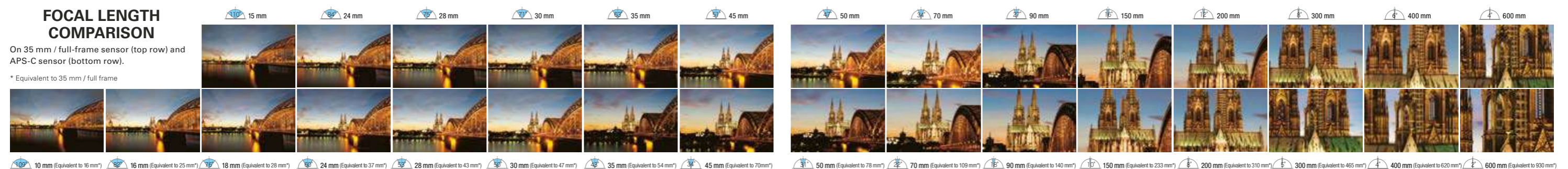

## Coatings

**BBAR** **BBAR G2** BBAR coating prevents reflection and scattering of light rays hitting the lens surface. It ensures natural color reproduction and prevents loss of brightness and contrast as well as unsightly ghosting. Since 2019, the advanced BBAR-G2 coating has been used.

**eBAND** The eBAND coating consists of an ultra-thin nanostructure (1 nm = 1 / 1,000,000 mm) with a very low refractive index. In combination with the underlying multi-coating, a remarkable anti-reflective effect is achieved.

**FLR** The fluorine coating protects the front lens from dirt and damage. Grease and water do not adhere to the surface and are easily removed.



## Autofocus

**RXD** The RXD technology (Rapid eXtra-silent Drive) is based on a stepper motor whose drive element controls the ideal angle of rotation precisely and silently. A sensor continuously determines the focus setting of the lens for this purpose. The powerful RXD motor keeps even dynamic objects continuously in focus.

**VXD** The VXD autofocus features the world's first linear focus motor developed by TAMRON and offers superior autofocus performance. Two VXD modules, acting in a floating system and controlled by electronic pulses, provide lightning-fast, precise and whisper-quiet focusing. The technology also guarantees improved AF tracking, for example in sports shots.

**USD** The USD (Ultrasonic Silent Drive) motors used in the SP series provide fast, precise and silent focusing. The technology is based on ultrasonic waves that are

converted into torque, and requires no gearing between the motor and the focus ring. This means that manual-intervention in focusing is possible at any time. The USD autofocus is suitable for fast and dynamic subjects, such as sports, wildlife and reportage photography.

**OSD** OSD (Optimized Silent Drive) technology is ideal for situations where absolute silence is required when shooting. The OSD autofocus is also particularly responsive and focuses very precisely even when tracking dynamic subjects.

**HLD** The HLD (High/Low torque modulated Drive) autofocus relies on an energy-saving motor with high drive torque to provide precise and smooth focusing. The arc-shaped HLD unit can be integrated into the lens body to save space and allows the construction of compact lenses.



# Equipment and construction

## Dual-MPU

**DMPU** TAMRON lenses with Dual-MPU (Micro-Processing Unit) have a powerful dual processor that ensures fast processing of the digital signals from autofocus and VC image stabilizer. The lens responds to the camera's commands at lightning speed. The result is very precise focusing, even in dynamic shooting situations, with highly accurate image stabilization at the same time.

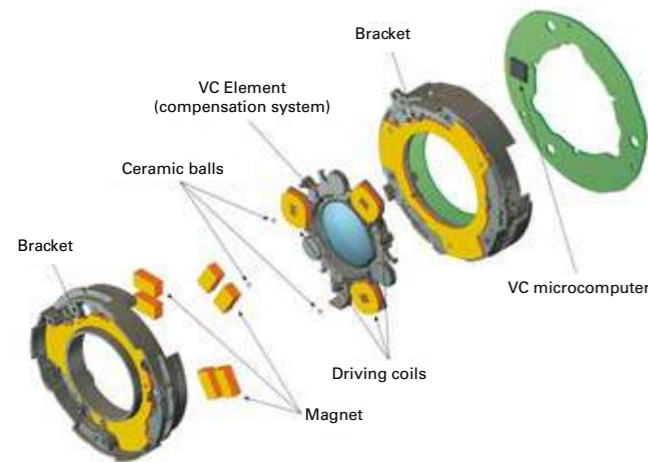

## Multiple cam mechanism

The Multiple-Cam mechanism enables smooth extension of the lens barrel. Precision curves in the cylindrical surface of the lens chassis ensure fine adjustments in the wide-angle range and constant movement in the telephoto range.

## Dynamic Rolling-Cam Mechanism

The Dynamic Rolling-Cam mechanism ensures fast and precise automatic focusing even for lenses with relatively heavy focus groups. The innovative technology ensures reliable autofocus performance even in the most demanding professional shooting situations (e.g. extremely cold or hot environments).

## Zoom lock mechanism

**ZL** The zoom lock mechanism, which can be operated by a switch, prevents unwanted extension of the lens barrel when not in use. The lock protects the lens from damage and still keeps it ready for use quickly.

## Splash water protection

**MR** Almost all TAMRON lenses have a weatherproof housing. The robust outer casing is effectively sealed against moisture penetration at all critical points (e.g. between focus ring and barrel or at the bayonet mount). This guarantees reliable functionality even under the most adverse outdoor shooting conditions.

## Optional accessories

### TAP-in Console\*

With the TAP-in Console and the free TAP-in Utility Software, the lens firmware can be updated and the functionality of the lenses can be customized. Among other things, this allows settings to be made that previously could only be made on-site at TAMRON service. Configurable parameters include: Focus adjustment, setting of the focus limiter, optimization of the manual focus function and adjustment of the VC image stabilizer.

Download TAP-in Utility Software:  
[www.tamron.co.jp/software/en/tapin/](http://www.tamron.co.jp/software/en/tapin/)

Tutorials for the TAP-in console can be found here:  
<https://bit.ly/tap-in-tutorial>



\* Compatible with SP 35mm F/1.4 Di USD, SP 70-200mm F/2.8 Di VC USD G2, 100-400mm F/4.5-6.3 Di VC USD, SP 150-600mm F/5-6.3 Di VC USD G2, 18-400mm F/3.5-6.3 Di II VC HLD

## VC-image stabilization

**VC** The VC (Vibration Compensation) mechanism developed by TAMRON compensates for unwanted camera movements without delay, ensuring razor-sharp images even in difficult lighting conditions. The image stabilizer is controlled by highly sensitive gyro sensors, which control the VC lens group resting on ball bearings. When shooting handheld, this allows up to 5 EV stops slower shutter speeds to be used. In addition, a significantly smoother viewfinder image is achieved in dynamic shooting situations.

## Internal focusing

**IF** In lenses with internal focusing, the extension length does not change when focusing. The filter ring also does not rotate with the barrel. This makes it easier to handle longer telephoto zoom lenses and to take photographs with polarizing and gradation filters. Other advantages are the shorter closest focusing distance over the entire focus range, reduced vignetting and reliable focusing.



# TAMRON Lens Utility

Maximize the potential of your lenses. With the TAMRON Lens Utility\* software, you can make numerous individual settings.

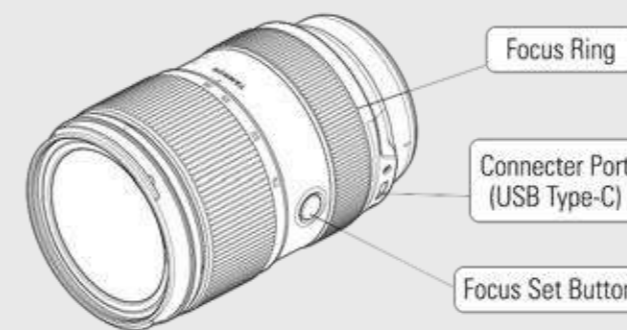

The new TAMRON Lens Utility software was developed by us to configure our own TAMRON lenses. After installing the program on a computer, compatible lenses can be connected to the computer via a connecting cable to customize various lens functions or to update the lens firmware.

Download TAMRON Lens Utility Software:  
[www.tamron.eu/service/tamron-lens-utility](http://www.tamron.eu/service/tamron-lens-utility)

## Function List

What you can do with TAMRON Lens Utility:

### A-B Focus

Lets you smoothly and easily shift Focus from one subject to another

### Focus Preset

Move focus to a prerecorded focal point with one click

### Focus Ring Function Setting

Makes manual focus easier to use

### Select AF / MF

Switch between Autofocus and Manual Focus

### Other Functions

Ring Function (Focus/Aperture) / Assign Function from the Camera

### Firmware Updates

Update your lens to the latest firmware version

\* Compatible with 28-75mm F/2.8 Di III VXD G2, 35-150mm F/2-2.8 Di III VXD



# Lens table

Status: February 2022

	Model	Focal length	Angle of view	Largest aperture	Smallest aperture	Aperture blades	Elements - Groups	Shortest Setting distance	Maximum magnification	Filter size	Weight <sup>4</sup>	Dimensions <sup>5</sup>	Connection	Lens hood	Notes
<b>Di III Lenses for Mirrorless System Cameras</b> Full frame and APS-C For Sony															
20mm F/2.8 Di III OSD M1:2	F050	20mm	94° 30'	F/2.8	F/22	7 <sup>1</sup>	10 – 9	11 cm	1:2	67 mm	220 g	73 × 64 mm	all Sony E-Mount	HF045	
24mm F/2.8 Di III OSD M1:2	F051	24mm	84° 04'	F/2.8	F/22	7 <sup>1</sup>	10 – 9	12 cm	1:2	67 mm	215 g	73 × 64 mm		HF051	
35mm F/2.8 Di III OSD M1:2	F053	35mm	63° 26'	F/2.8	F/22	7 <sup>1</sup>	9 – 8	15 cm	1:2	67 mm	210 g	73 × 64 mm		HF053	
17-28mm F/2.8 Di III RXD	A046	17-28mm	103° 41' – 75° 23'	F/2.8	F/22	9 <sup>1</sup>	13 – 11	15 – 24 cm	1:5,2 – 1:6	67 mm	420 g	73 × 99 mm		HA046	
28-75mm F/2.8 Di III VXD G2	A063	28-75mm	75° 23' – 32° 11'	F/2.8	F/22	7 <sup>1</sup>	17 – 15	18 – 38 cm	1:2,7 – 1:4,1	67 mm	540 g	75,8 × 117,6 mm		HA063	TAMRON Lens Utility compatible
28-200mm F/2.8-5.6 Di III RXD	A071	28-200mm	75° 23' – 12° 21'	F/2.8	F/16–32	7 <sup>1</sup>	18 – 14	19 – 80 cm	1:3,1 – 1:3,8	67 mm	575 g	74 × 117 mm		HA071	
35-150mm F/2-2.8 Di III VXD	A058	35-150mm	63° 26' – 16° 25'	F/2-2.8	F/16–22	9 <sup>1</sup>	21 – 15	33 – 85 cm	1:5,7 – 1:5,9	82 mm	1.165 g	89,2 × 158 mm		HA058	TAMRON Lens Utility compatible
70-180mm F/2.8 Di III VXD	A056	70-180mm	34° 21' – 13° 42'	F/2.8	F/22	9 <sup>1</sup>	19 – 14	(27 – )85 cm <sup>3</sup>	(1:2 – )1:4,6 <sup>3</sup>	67 mm	810 g	81 × 149 mm		HA056	
70-300mm F/4.5-6.3 Di III RXD	A047	70-300mm	34° 21' – 8° 15'	F/4.5-6.3	F/22–32	7	15 – 10	80 – 150 cm	1:9,4 – 1:5,1	67 mm	545 g	77 × 148 mm		HA047	
150-500mm F/5-6.7 Di III VC VXD	A057	150-500mm	16° 25' – 4° 57'	F/5-6.7	F/22–32	7	25 – 16	60 – 180 cm	1:3,1 – 1:3,7	82 mm	1.880 g	93 × 209,6 mm	HA057		
<b>Di III-A Lenses for mirrorless system cameras</b> APS-C For Sony and Fujifilm															
11-20mm F/2.8 Di III-A RXD	B060	11-20mm	105° 20' – 71° 35'	F/2.8	F/16	7	10 – 12	15 – 24 cm	1:4 – 1:7,6	67 mm	335 g	73 × 86,2 mm	Sony E-Mount	HF036	
17-70mm F/2.8 Di III-A VC RXD	B070	17-70mm	79° 55' – 23° 00'	F/2.8	F/22	9 <sup>1</sup>	12 – 16	19 – 39 cm	1:4,8 – 1:5,2	67 mm	525 g	74,6 × 119,3 mm	Sony E-Mount	HB060	
18-300mm F/3.5-6.3 Di III-A VC VXD	B061	18-300mm	77° 24' – 5° 30'	F/3.5-6.3	F/22–40	7	15 – 19	15 – 99 cm	1:5 – 1:4	67 mm	620 g	75,5 × 125,6 mm	Sony E-Mount Fujifilm X-Mount	HB061	
<b>Di Lenses for digital SLR cameras</b> Full frame and APS-C For Canon and Nikon															
SP 35mm F/1.4 Di USD	F045	35mm	63° 26'	F/1.4	F/16	9 <sup>1</sup>	14 – 10	30 cm	1:5	72 mm	805 g	80,9 × 102,3 mm	all Canon DSLR/ Nikon DSLR	HF045	TAP-in-Konsole compatible
SP 24-70mm F/2.8 Di VC USD G2	A032	24-70mm	84° 04' – 34° 21'	F/2.8	F/22	9 <sup>1</sup>	17 – 12	38 cm <sup>2</sup>	1:5	82 mm	900 g	88,4 × 108,5 mm		HA032	
SP 70-200mm F/2.8 Di VC USD G2	A025	70-200mm	34° 21' – 12° 21'	F/2.8	F/22	9 <sup>1</sup>	23 – 17	95 cm <sup>2</sup>	1:6,1	77 mm	1.485 g	88 × 191,3 mm		HA025	TAP-in-Konsole compatible
100-400mm F/4.5-6.3 Di VC USD	A035	100-400mm	24° 24' – 6° 12'	F/4.5-6.3	F/32–45	9 <sup>1</sup>	17 – 11	150 cm <sup>2</sup>	1:3,6	67 mm	1.115 g	86,2 × 196,5 mm		HA035	TAP-in-Konsole compatible, Tripod clamp optionally available
SP 150-600mm F/5-6.3 Di VC USD G2	A022	150-600mm	16° 25' – 4° 80'	F/5-6.3	F/32–40	9 <sup>1</sup>	21 – 13	220 cm <sup>2</sup>	1:3,9	95 mm	1.990 g	108,4 × 257,7 mm		HA022	TAP-in-Konsole compatible
<b>Di II Lenses for digital SLR cameras</b> APS-C For Canon and Nikon															
18-200mm F/3.5-6.3 Di II VC	B018	18-200mm	75° 33' – 7° 59'	F/3.5-6.3	F/22–40	7 <sup>1</sup>	16 – 14	49 – 77 cm	1:4	62 mm	400 g	75 × 94,1 mm	all Canon DSLR/ Nikon DSLR	HB018	
18-400mm F/3.5-6.3 Di II VC HLD	B028	18-400mm	75° 33' – 4° 00'	F/3.5-6.3	F/22–40	7 <sup>1</sup>	16 – 11	45 cm <sup>2</sup>	1:2,9	72 mm	705 g	79 × 121,4 mm	HB028	TAP-in-Konsole compatible	

1 The blades form an almost circular shape at open aperture. This shape is largely maintained even when stopping down by up to two stops.  
 2 Shortest focusing distance over the entire focal length range.  
 3 Bracketing value equals shortest focusing distance with manual focus (MF)  
 4 Weight including detachable tripod clamp. The weight specifications for Di and Di-II lenses refer to the model with Nikon mount.  
 5 Length is defined as the distance from the contact surface on the camera body to the lens tip. The diameter and length specifications for Di and Di-II lenses refer to the model with Nikon mount.

If the camera displays an error message or the LCD monitor remains black when using lenses with a Canon mount, the signal transmission between the camera and lens may not be working correctly and in very rare cases malfunction may occur. To solve the problem, please proceed as follows. 1: turn off the camera. Make sure that there is no dirt on the signal contact points of the lens and the camera. 3. If the problem still occurs, please turn off the camera and remove the battery. Reinsert the battery and activate the camera again.

## Compatibility with Canon EOS R/Nikon Z

Information on the use of TAMRON lenses with mirrorless system cameras of the Canon EOS R or Nikon Z series under: [www.tamron.eu/service/compatibility-nikon-z-and-canon-eos-r](http://www.tamron.eu/service/compatibility-nikon-z-and-canon-eos-r)

## Lens hood

All TAMRON lenses are delivered with an adapted lens hood. The lens attachment prevents light rays penetrating from the side from causing stray light and reflections in the lens and thus impairing the image quality.



# TAMRON

Focus on the Future

TAMRON Europe GmbH  
Robert-Bosch-Str. 9, 50769 Cologne  
Tel. +49 (0) 221 669544-0  
info@tamron.de

[www.tamron.eu](http://www.tamron.eu)

## TAMRON BLOG

News, interviews  
and reports from the  
TAMRON world can be  
found you can also find  
online.

[www.tamron.eu/  
magazine/blog](http://www.tamron.eu/magazine/blog)

## FOLLOW TAMRON!

 **FACEBOOK**  
[www.facebook.com/TAMRONobjektive](http://www.facebook.com/TAMRONobjektive)

 **INSTAGRAM**  
[www.instagram.com/TAMRON\\_deutschland](http://www.instagram.com/TAMRON_deutschland)

 **TWITTER**  
[www.twitter.com/TAMRONobjektive](http://www.twitter.com/TAMRONobjektive)

 **YOUTUBE**  
[www.youtube.com/user/TAMRONEurope](http://www.youtube.com/user/TAMRONEurope)